

JOB NAME _____

TYPE _____

CATALOG NUMBER _____

Steplites

3500 SERIES

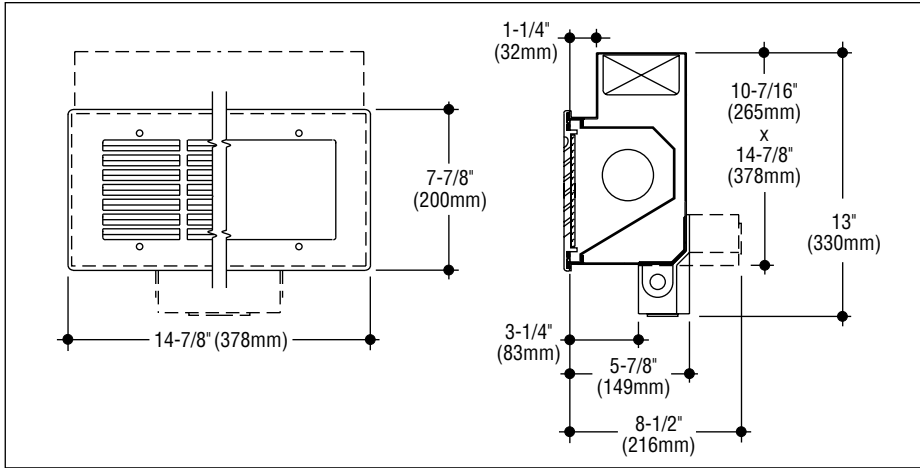

SPECIFICATIONS

Construction

- Fixture housing is constructed from die-formed 16 gauge electro-galvanized steel finished with a white polyester coating
- Faceplate is cast aluminum with metallic aluminum powder coating, gasketed and retained by stainless steel screws
- Diffuser is frosted tempered glass set in silicone sealant
- Reflector is constructed of white die-formed aluminum
- Standard junction box is cast aluminum with polyester coating
- cETLus listed, suitable for wet locations, in concrete pour/block wall construction.

Electrical

- Fixture is wired for one medium base high pressure sodium or metal halide lamp. Metal halide electronic ballasts are universal voltage
- High pressure sodium ballasts are magnetic only
- Junction box allows 8 wire thru-wiring, four in and four out. Provided with two 1/2" tapped conduit entrances in the bottom and one 1/2" conduit entrance in each side.

Mounting

Housing has flanges with holes for mounting to concrete forms or masonry materials.

Catalog Numbers

Lamps

70W high pressure sodium, medium base
70W metal halide, medium base

Faceplate

Louver

Non-Louvered

<input type="checkbox"/> HPS3570W	<input type="checkbox"/> HPS3570GW
<input type="checkbox"/> HMH3570W	<input type="checkbox"/> HMH 570GW

Photometric data available for Steplites can be downloaded at: www.colelighting.com/downloads/1

Options

Bronze faceplate: Satin finished, clear coated.
Add suffix -B.
Tamperproof screws: Socket head faceplate screws. Add suffix -TP.
Alternate Faceplate Color: Black or white.
Add suffix -BLK or -WHT.

How to Specify

1. Select catalog number with desired features.
2. Add suffixes for options required to meet job conditions.



C.W. Cole & Company, Inc.
2560 N. Rosemead Boulevard
South El Monte, CA 91733-1593

Tel. (626) 443-2473
Fax (626) 443-9253
info@colelighting.com
www.colelighting.com