

# Installation Instruction Sheet

CATALOG NO.: TLS-351-W

## STEP 1

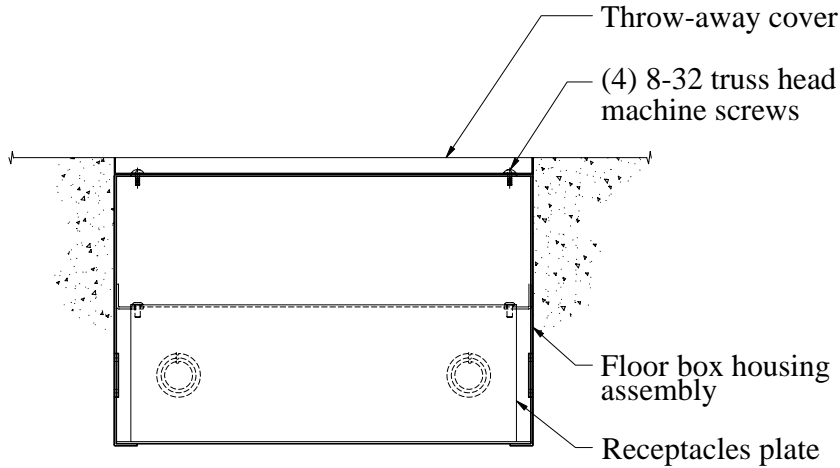

SET FLOOR BOX HOUSING IN POSITION FOR CONCRETE POUR.

REMOVE THROW-AWAY COVER TO GAIN ACCESS TO RECEPTACLE PLATE, REMOVE RECEPTACLE PLATE, RUN FEED WIRES AND CONNECT CONDUIT.

REINSTALL THROW-AWAY COVER, LEVEL WITH FINISH CONCRETE SURFACE.

SIDES OF THROW-AWAY COVER SHOULD BE TREATED FOR EASY REMOVAL AFTER CONCRETE HAS HARDENED.

## STEP 2

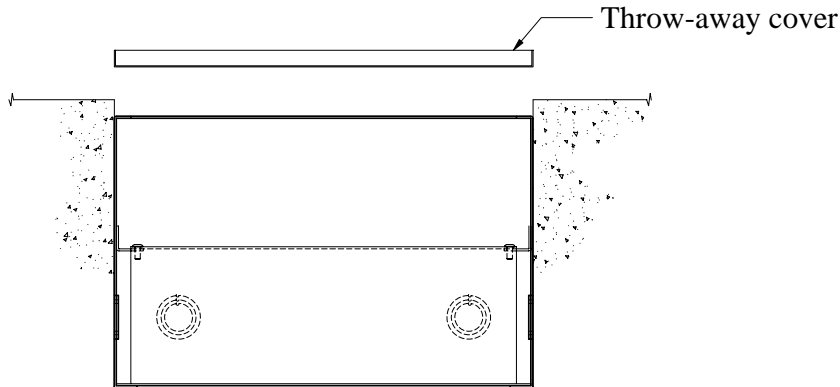

WHEN CONCRETE IS FULLY SET, REMOVE AND DISCARD THROW-AWAY COVER & (4) 8-32 TRUSS HEAD MACHINE SCREWS.

## STEP 3

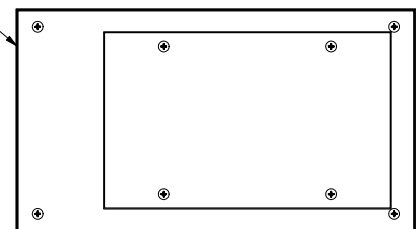
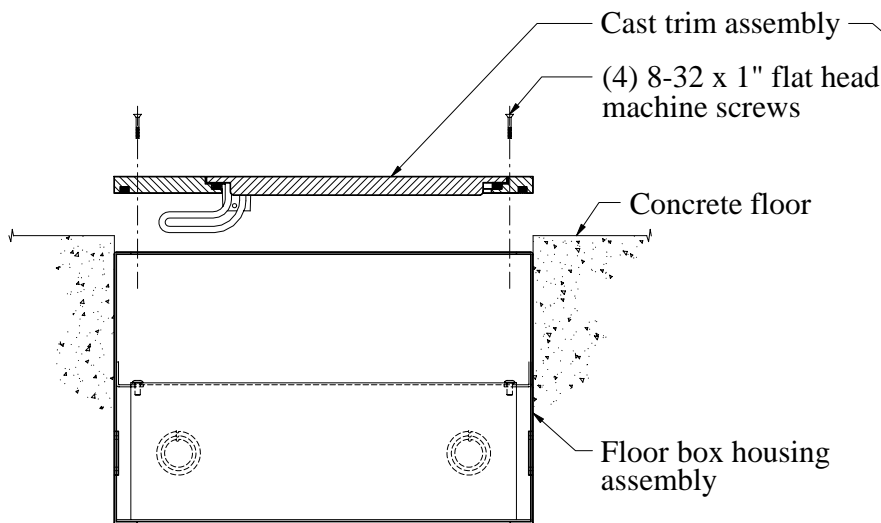

INSERT CAST COVER ASSEMBLY INTO HOUSING & SECURE IN PLACE WITH (4) 8-32 x 1" FLAT HD. MACHINE SCREWS PROVIDED.

### NOTE:

\* THIS PRODUCT MUST BE INSTALLED IN ACCORDANCE WITH THE APPLICABLE INSTALLATION CODE BY A PERSON FAMILIAR WITH THE CONSTRUCTION AND OPERATION OF THE PRODUCT AND THE HAZARDS INVOLVED.

\* CONTACT WITH ACID-WASH OF ANY TYPE TO ANY SURFACE OF STEPLIGHT WILL / MAY VOID WARRANTY.

\* RECESSED HOUSING NOT SEALED FROM MOISTURE. PROTECTION MUST BE PROVIDED TO PREVENT WATER FROM ENTERING HOUSING.

**COLE**  
*Lighting*